

CERTIFICATE OF OWNERSHIP AND DEDICATION

I (we) John H. Baker - Trustee

Owner(s) and Developer(s) of the land shown on this plat, and designated herein as the Briarcrest Commercial Subdivision, Lot 1 & 2, Block One to the City of Bryan, Texas, and whose name(s) is/are subscribed hereto, hereby dedicate to the use of the public forever all streets, alleys, parks, water courses, drains, easements and public places thereon shown for the purpose and consideration therein expressed.

STATE OF TEXAS
COUNTY OF HARRIS

Before me, the undersigned authority, on this day personally appeared John H. Baker

known to me to be the person (s) whose name (s) is/are subscribed to the foregoing instrument, and acknowledged to me that he/they executed the same for the purpose and consideration therein stated.

Given under my hand and seal on this 300 day of October 19 78.

(seal)

Jerry M. Bishop
Notary Public, Harris County, Texas
Jerry M. Bishop

CERTIFICATION OF THE SURVEYOR

STATE OF TEXAS
COUNTY OF BRAZOS

I, Jerry Bishop, Registered Professional Engineer No. 37426 in the State of Texas, hereby certify that this plat is true and correct and was prepared from an actual survey of the property made under my supervision on the ground.

Jerry Bishop
Registered Professional Engineer

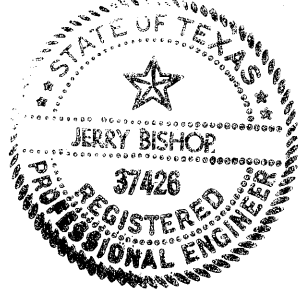

CERTIFICATION BY THE ENGINEER:

STATE OF TEXAS
COUNTY OF BRAZOS

I, Jerry Bishop, Registered Professional Engineer No. 37426 in the State of Texas, hereby certify that proper engineering consideration has been given this plat.

Jerry Bishop
Registered Professional Engineer

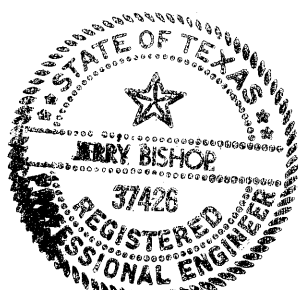

APPROVAL OF THE PLANNING COMMISSION:

I, D. D. Williamson, Chairman of the City Planning Commission of the City of Bryan, State of Texas, hereby certify that the attached plat was duly filed for approval with the City Planning Commission of the City of Bryan on the 9 day of October, 19 78 and same was duly approved on the 19 day of October, 19 78, by said Commission.

D. D. Williamson
Chairman, City Planning Commission
Bryan, Texas

CERTIFICATE BY THE CITY PLANNER:

I, the undersigned, City Planner of the City of Bryan, hereby certify that this subdivision plat conforms to all requirements of the subdivision regulations of the City of Bryan, Texas.

D. D. Williamson
City Planner
City of Bryan, Texas

CERTIFICATE BY THE COUNTY CLERK:

STATE OF TEXAS
COUNTY OF BRAZOS

I, Frank Coriarte, County Clerk, in and for the said County, do hereby certify that this plat together with its certificates of authentication was filed for record in my office the 24 day of September, 19 78, in the Deed Records of Brazos County, Volume 111, Page 111.

Frank Coriarte
County Clerk, Brazos County, Texas

BRAZOS VALLEY
REHABILITATION CENTER
D.R. VOL. 256, PG. 287

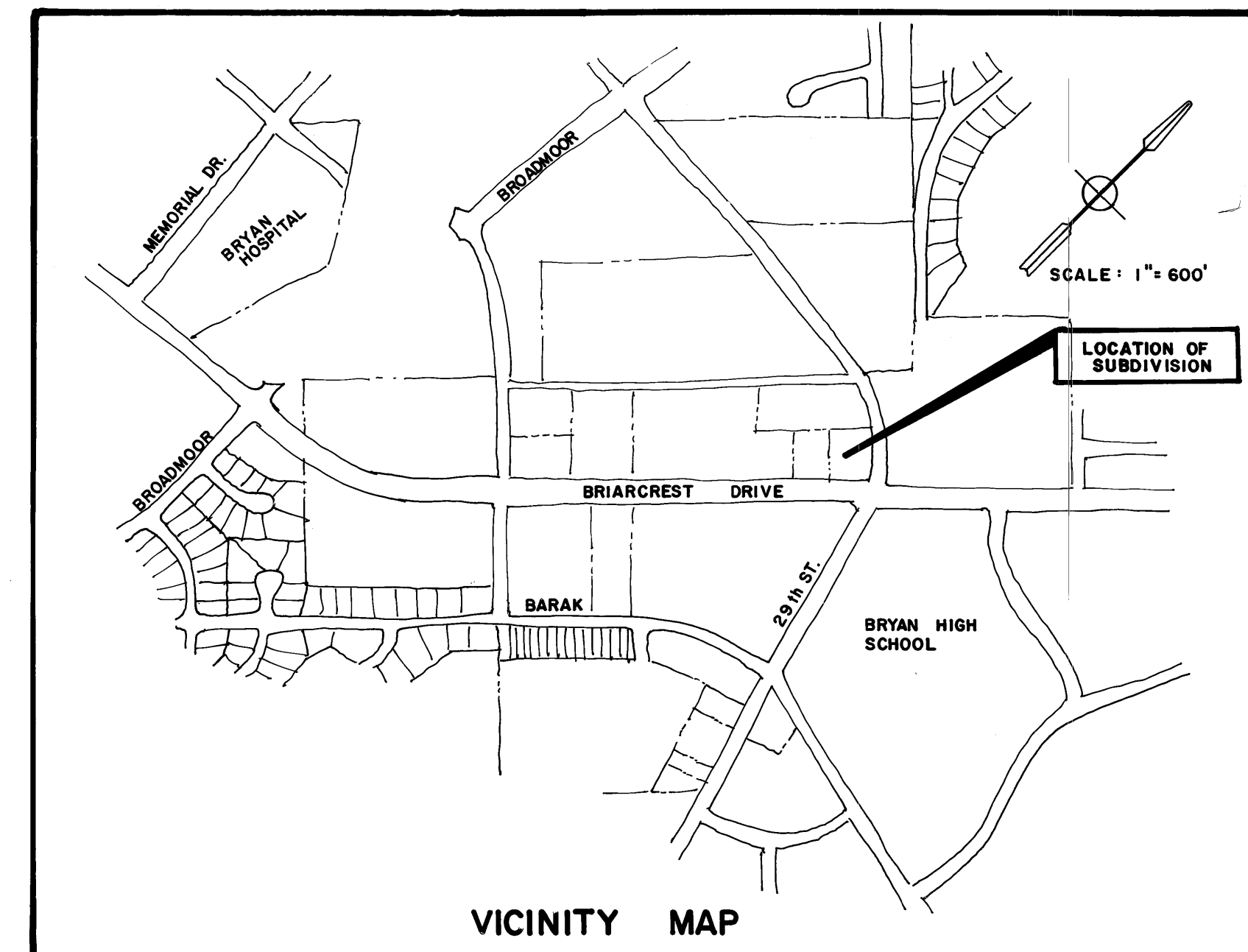
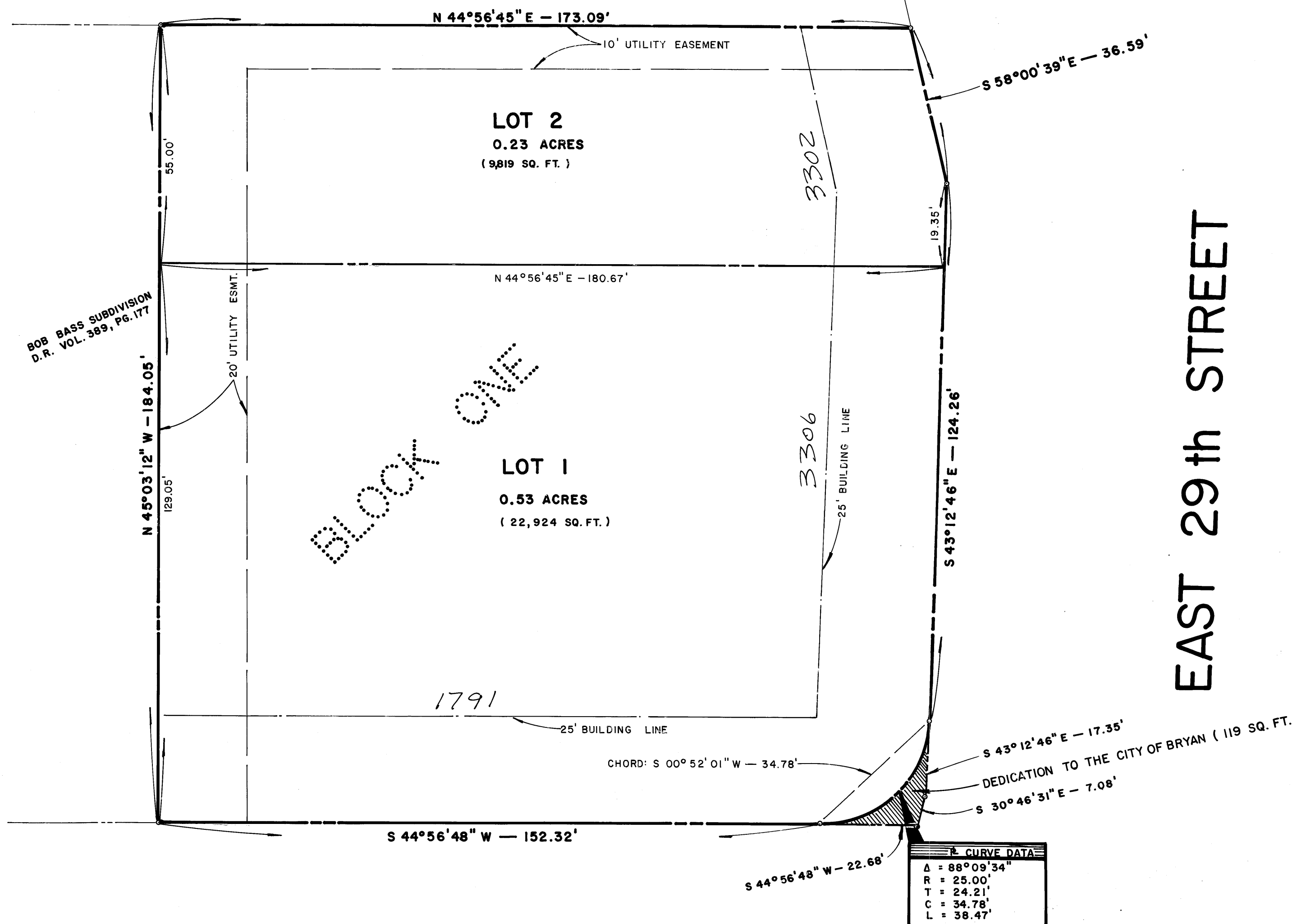
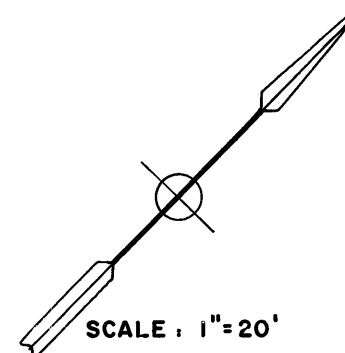

on base 9/13/61 wo

GENERAL NOTES
5' MINIMUM SIDEYARD SETBACK

FINAL PLAT

**BRIARCREST COMMERCIAL
SUBDIVISION**
LOTS 1 & 2, BLOCK ONE
0.75 ACRES
JOHN AUSTIN LEAGUE, ABSTRACT NUMBER TWO
BRYAN, BRAZOS COUNTY, TEXAS
SCALE: 1" = 20'
SEPTEMBER 1978

PREPARED BY: JERRY BISHOP & ASSOCIATES, INC.
1804 WELSH STREET
COLLEGE STATION, TEXAS 77840